

MCQVL series

END LOCK CYLINDERS

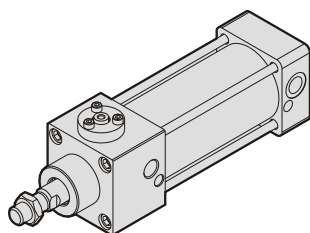

End lock type



R: Rod cover

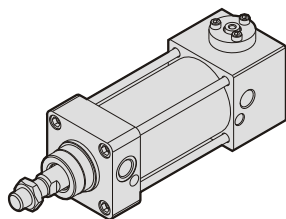

H: Head cover

Order example:

MCQVL-11-63-100(M)-R

MODEL

TUBE I.D.

M: Magnet

1: Single Rod

STROKE

END LOCK TYPE

R: Rod cover
H: Head cover

STYLE:

Code	Symbol	Description
1 1		Double acting / Male thread

Features

■ Non-lubrication:

Designs of oil-filled alloy, special housing and bushing provide the needed self-lubrication of piston rod.

■ High quality-long service life:

Hard anodized aluminum cylinder tubes resist corrosion and abrasion.

■ ISO-VDMA Standard specification:

Conformance to ISO-6431 & VDMA-24562 specification. Unified design, most parts of each type are interchangeable among each other.

■ Port thread PT. NPT. are also available.

Specification

Model	MCQVL	
Tube I.D. (mm)	63	80
Medium	Air	
Operating pressure range	0.5~9.9 kgf/cm ²	
Proof pressure	15 kgf/cm ²	
Ambient temperature	-5~+60°C (No freezing)	
Sensor switch	RCA	
Sensor switch holder	HV2	HV3

Table for standard stroke

Tube I.D.	Stroke (mm)
φ 63,80	50,75,100,125,150,175,200,250,300,350,400,450,500,600

- Stroke out of specification is also available.
- Please consult us if stroke out of specification.

Use Recommended Air Pressure Circuit.

- It is necessary to make it lock and unlock properly.

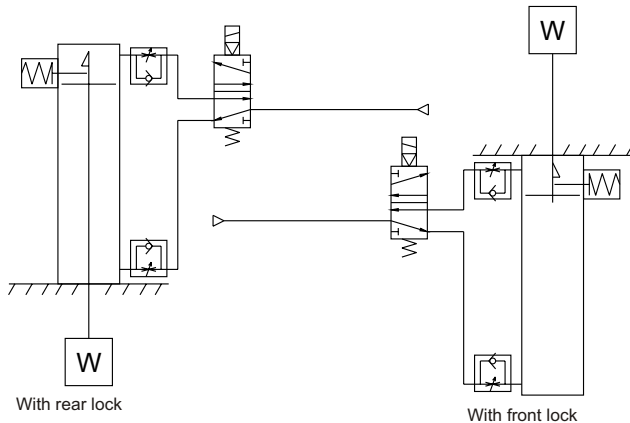

Operating precautions

- Do not use a 3 position solenoid valve.**
Avoid using this cylinder in combination with a 3 position solenoid valve (particularly the closed center metal seal style). If air pressure becomes sealed inside the port on the side that contains the lock mechanism, the lock will not engage. Even if the lock is engaged at first, the air that leaks from the solenoid valve could enter the cylinder and cause the lock to disengage as time elapses.
- Back pressure is necessary for unlocking.**
Before starting, make sure that air is supplied to the side that is not equipped with a lock mechanism as shown in the diagram above (or the side on which the piston rod is unlocked, if both sides are equipped with a lock). Otherwise, the lock may not disengage.
(☞Refer to "Regarding lock disengagement".)
- Disengage the lock before installing or adjusting the cylinder.**
The lock could become damaged if the cylinder is installed with its lock engaged.
- Operate the cylinder at a load ratio of 50% or less.**
The lock might not disengage or might become damaged if a load Ratio of 50% is exceeded.
- Do not synchronize multiple cylinders.**
Do not operate two or more end lock cylinders synchronized to move a single workpiece because, one of the cylinder locks may not be able to disengage when required.
- Operate the speed controller under meter-out control.**
If operated under meter-in control, the lock might not disengage.
- On the side that has a lock, make sure to operate at the stroke end of the cylinder.**
The lock might not engage or disengage if the piston in the cylinder has not reached the stroke end.

Operating Pressure

- Supply air pressure of 0.15MPa or higher to the port on the side that has the lock mechanism, as it is necessary for disengaging the lock.

The Exhaust Air Speed

- The lock will engage automatically if the air pressure at the port on the side that has the lock mechanism becomes 0.05MPa or less. Be aware that if the piping on the side that has the lock mechanism is narrow and long, or if the speed controller is located far from the cylinder port, the exhaust air speed could become slower, involving a longer time for the lock to engage. A similar result will ensue if the silencer that is installed on the exhaust port of the solenoid valve becomes clogged.

The Relationship between the Lock and the Cushion

- When the cushion valve on the side with the lock mechanism is fully closed or almost closed, the piston rod might not be able to reach the stroke end. Thus, the lock will not engage. Furthermore, if the lock becomes engaged when the cushion valve is almost fully closed, it might not be possible for the lock to disengage. Therefore, the cushion valve must be adjusted properly.

Lock Disengagement

- To disengage the lock, make sure to supply air pressure to the port on the side without a lock mechanism, thus preventing the load from being applied to the lock mechanism. (Refer to the recommended air pressure circuit.) If the lock is disengaged when the port on the side that does not contain a lock mechanism is in the exhausted state and the load is being applied to the lock mechanism, undue force will be applied to the lock mechanism, and it may damage the lock mechanism. Also, it could be extremely dangerous, because the piston rod could move suddenly.

END LOCK CYLINDERS

Manual Disengagement

- Insert the bolt and screw the bolt into the lock piston rod and pull the bolt to disengage the lock.
Releasing the bolt will re-engage the lock.
The bolt size, pulling force, and the stroke are listed below.

Model	Thread size	Pulling force	Stroke (mm)
MCQVL-63	M6×1.0×20 ℓ	24.5 N	4
MCQVL-80	M6×1.0×20 ℓ	24.5 N	5

Bolt should be detached under normal operation, otherwise it may cause malfunction of the locking feature.

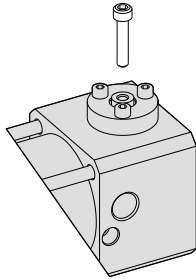

Installation of sensor switch

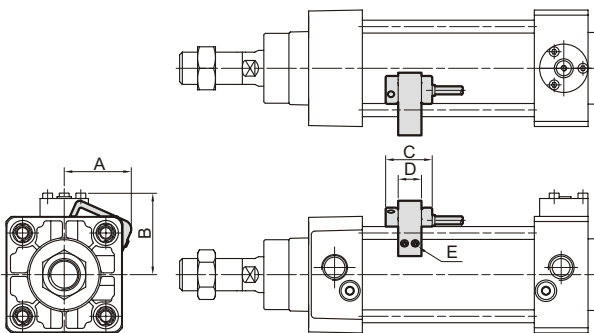
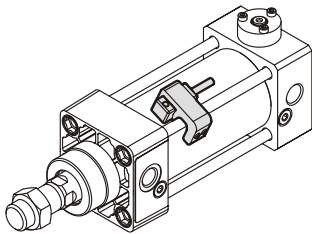

Code Tube I.D.	Sensor switch	Hold	A	B	C	D	E
63	RCA	HV2	42.5	50	26	13	M4×10L
80	RCA	HV3	49.5	60	26	13	M4×10L

Operation Principles

- For the rear lock (the same as the front lock)

- When the piston rod nears the stroke end, the tapered portion (* mark) at one end of the piston rod pushes the lock piston rod upward.

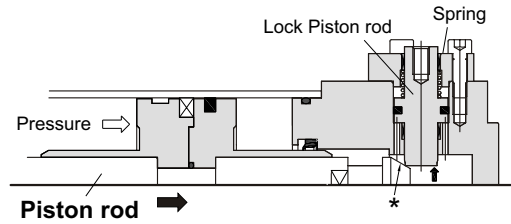

- The lock piston rod is pushed further upward.

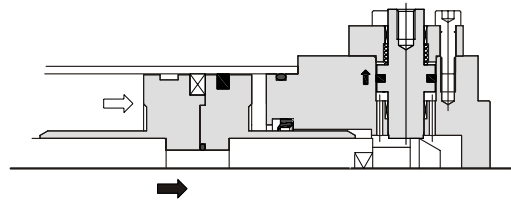

- The lock becomes engaged as the lock piston rod falls into the groove portion of the piston rod. (A spring force keeps the lock piston pushed down.) At this time, the port on the head side is in the discharged state and is at atmospheric pressure.

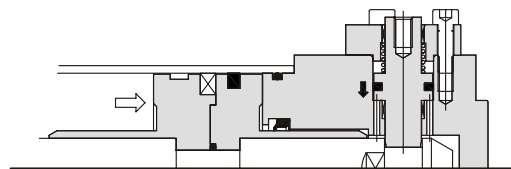

- When air pressure is supplied to the head side, this pressure pushes the lock piston upward to disengage the lock.

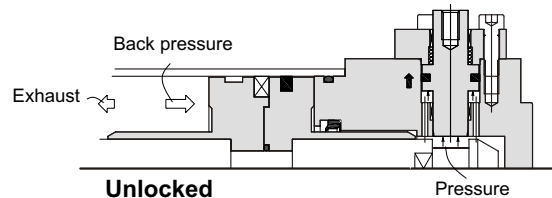

- As the lock has been disengaged, the cylinder moves forward.

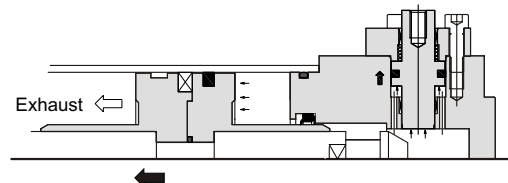

MCQVL Dimensions $\phi 63, \phi 80$

END LOCK CYLINDERS



R

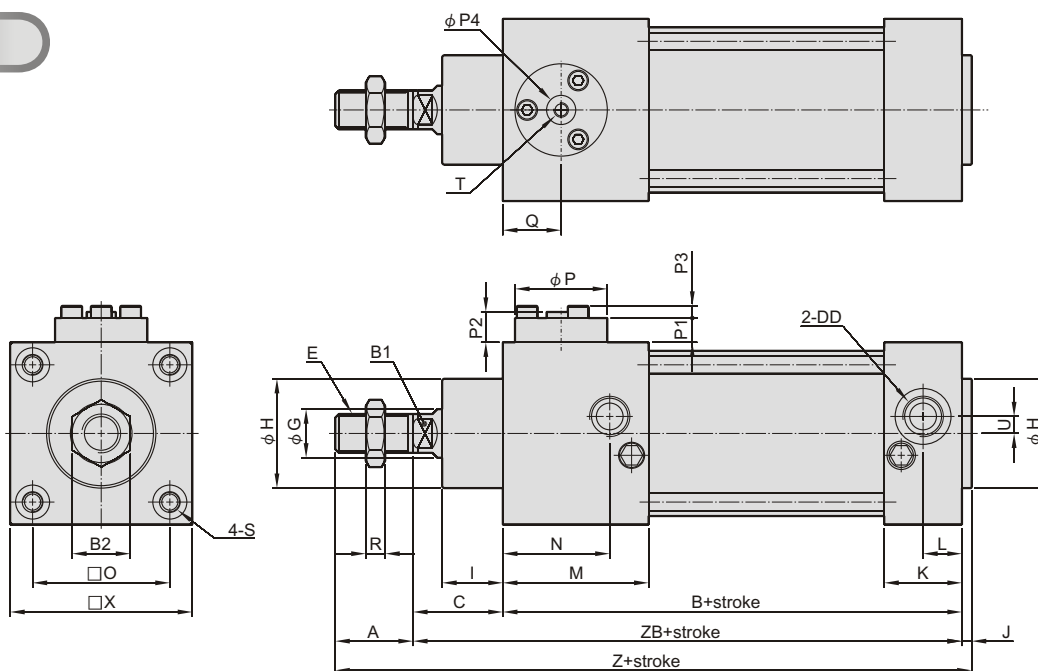

H

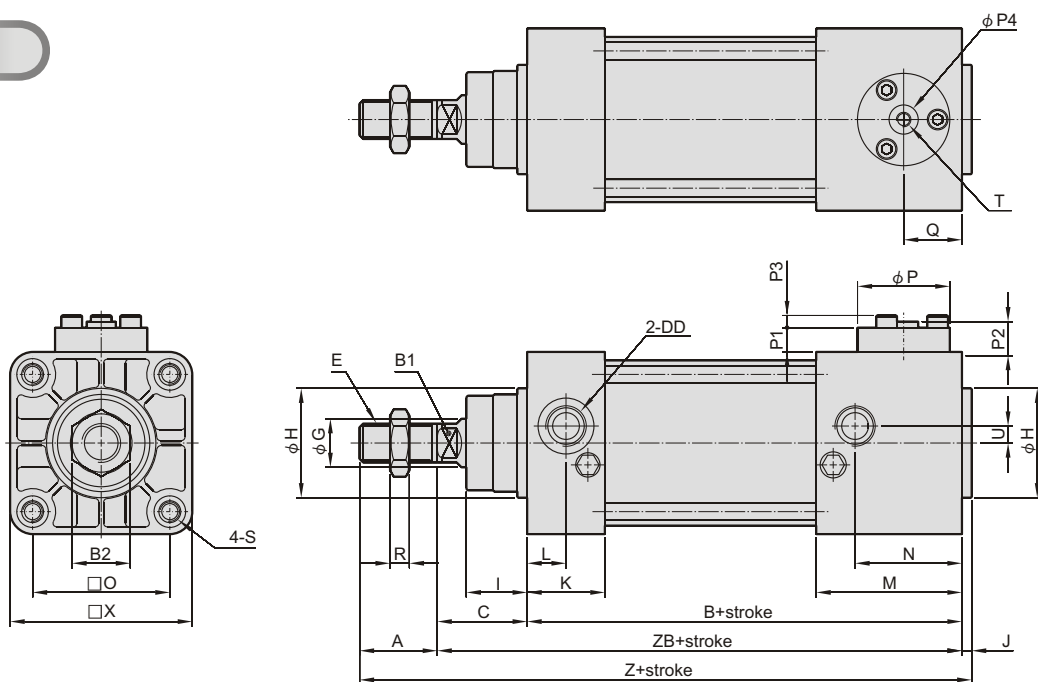

Code Tube I.D.	A	B	B1	B2	C	DD	E	G	H	I	J	K	L	M	N	O	P	P1	P2	P3	P4	R	Q
63	32	149	16	24	37	G 3/8	M16 × 1.5	20	45	25	4	32	16	60	46	56.5	38	11	12.5	5	12	8	24
80	40	168	21	30	46	G 3/8	M20 × 1.5	25	45	32	4	38	19	78	59	72	50	12	16	0	14	10	26

Code Tube I.D.	T	S	U	X	Z	ZB
63	M6 × 1.0	M8 × 1.25	7	75	222	186
80	M6 × 1.0	M10 × 1.5	7	95	258	214